

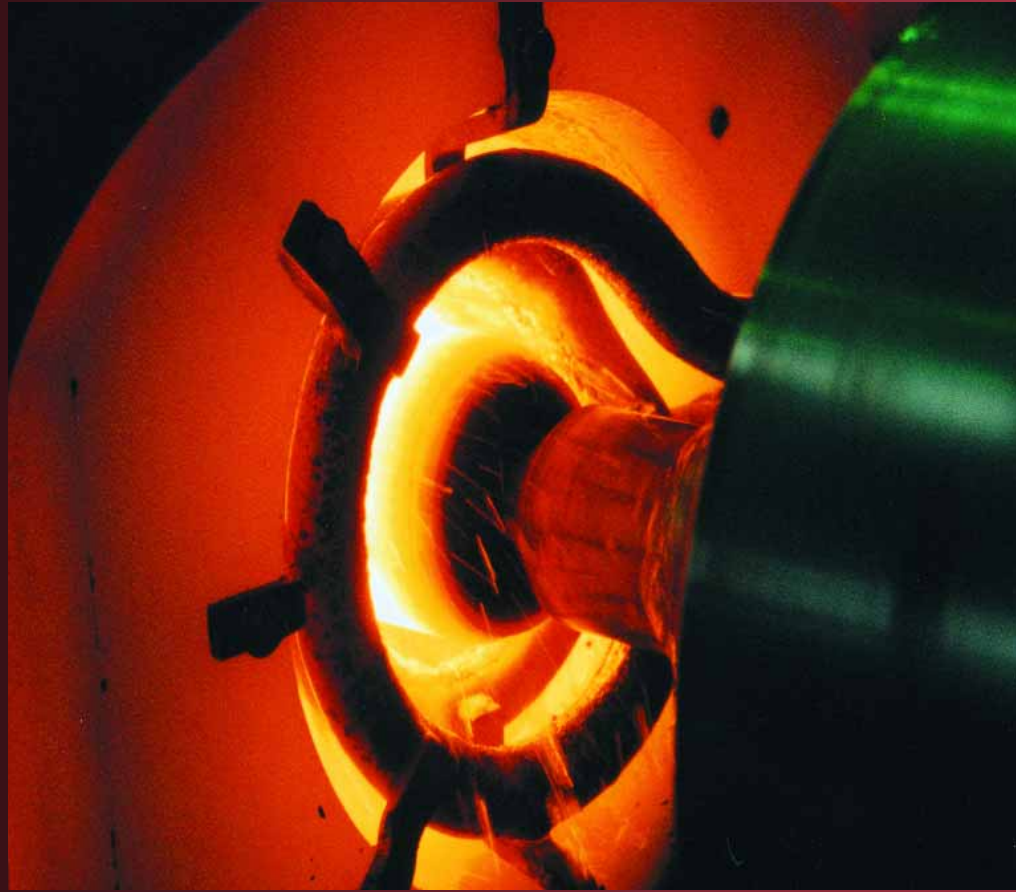

# Induction Heat Treating

HEAT TREATING



# An Introduction to Heat Engineered Solutions



Induction heat treating has become an essential operation in the development of manufacturing cells. There is no longer a need to have floor space assigned for part storage. Repetitive handling has been virtually eliminated. Parts are processed sequentially, usually one or two at a time, with precise control over every operating variable in the heat treating process. In addition, a well-documented part history can be maintained for each and every part providing accurate records that today's customers demand.



Creative inductor developments and the use of computer-assisted designs have rapidly expanded the range of induction heat treating applications. Induction heating has proven to be fast, energy efficient, easily controlled, and puts the heat where you want it when you want it. There is no idle time and no massive refractory to heat and cool as there is with traditional batch furnaces.



Innovation and technology is only part of the offering Ajax TOCCO provides to the market. Equipment performance and reliability are equally important in any manufacturing environment. We make the extra effort to design into our systems the integrity needed for reliable operation under high production conditions. Each system is fully tested. Our metallurgical staff assures process parameters are satisfied before the equipment is shipped. If customer support is required after shipment, Ajax TOCCO provides a range of aftermarket services including technical assistance and service using our 24 hour service hotline. Multiple repair centers located around the world offer extensive inductor repair, equipment maintenance and operator training.

## Ajax TOCCO Magnethermic® Corporation

*The Global Force in Induction Technology*

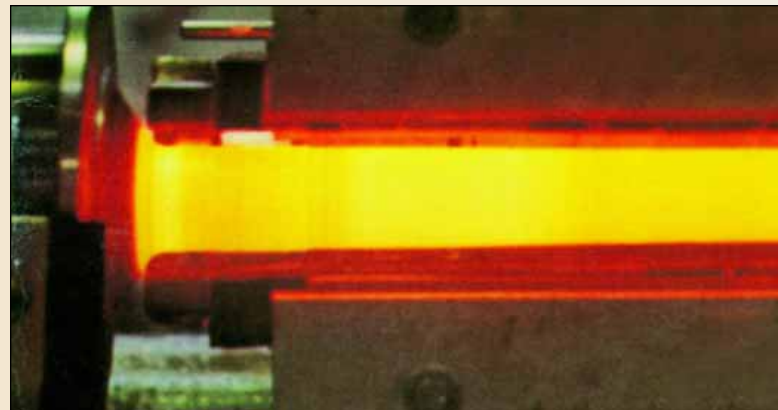

# INDUCTION HEAT

# Treating

## Induction Heat Treating Advantages

Induction heating systems provide a fast, efficient and economical method of heating any electrically conductive material to a precise temperature. The equipment utilizes clean, readily available electric power to heat the entire surface of the work piece or selected specific areas. Heat depth can be limited to just the surface or can include the entire cross section. Temperatures are accurately controlled to meet the specific requirements of the application.

Induction heat treating is equally efficient for job shop or high production operations. Since induction heating is clean and radiated heat is minimized, the process heating system can be installed directly in your production line or general work area. The equipment is compatible with existing in-plant material handling systems, and can be automated to meet specific production requirements. Typical advantages are:

### Increased Production

- Fast localized heating reduces the processing time to seconds. Reduced heat and quench times.
- Compared with carburizing, induction hardening eliminates copper masking, packing, straightening and extra machining operations.
- Compact machines can be located close to related operations to avoid handling and reduce part inventories.
- Set-up changes for different parts are quick and easy.
- Machines either pace the operator, or are completely automated.

### Lower Costs

- Scrap is reduced or eliminated by the use of precise controls.
- Distortion is minimized.
- Use of costly alloy steels is reduced or eliminated.
- Carburizing costs are eliminated.
- Warm-up time is eliminated, since power is on only during the heating cycle.
- Need for skilled labor is eliminated.
- Man-hours are reduced with high production rates.
- Working conditions are improved.
- Maintenance costs are reduced.
- Less floor space is needed.

### Improved Products

- Localized heating and hardening minimize distortion.
- Surface hardening retains original ductility of core.
- The hardened area is accurately controlled in respect to case depth, width, location and hardness.

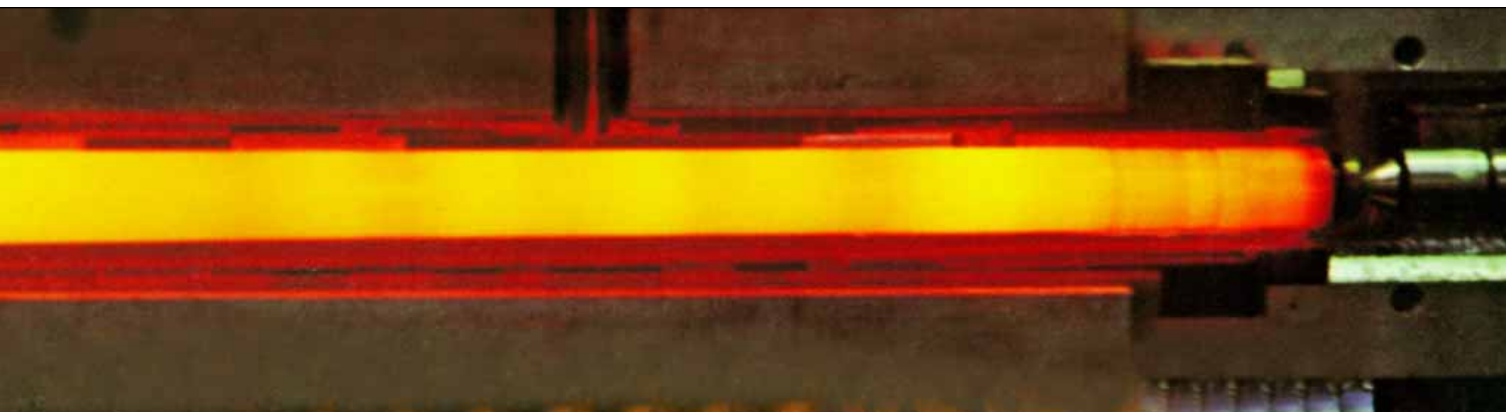

# TREATING

# Heat Treating Fundamentals

## Isothermal Transformation Diagram

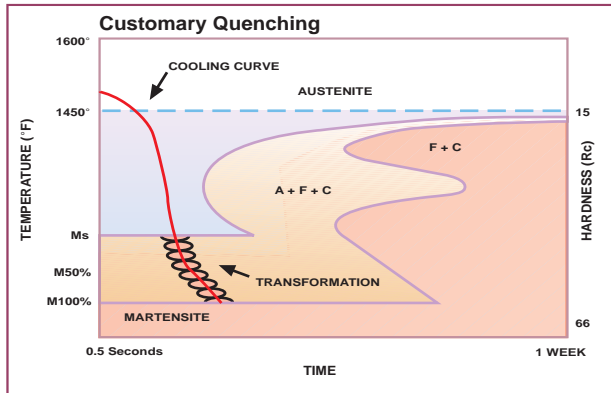

## Hardness & Hardening Temperature vs Carbon

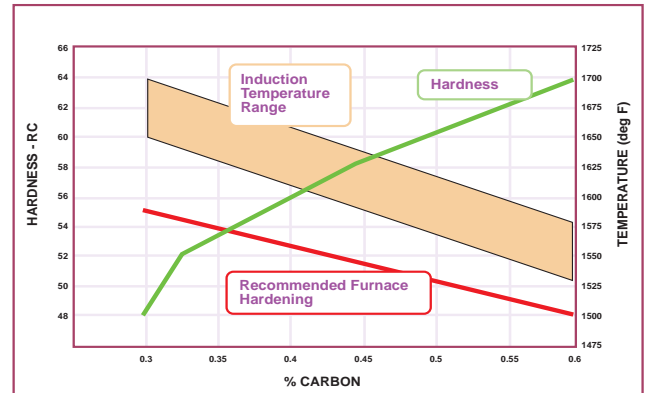

## Induction Hardening 1045 Steel

	Affected depth, in.			Hardened depth, in.*			Heating time, sec.		
	3,000Hz	10,000Hz	500kHz	3,000Hz	10,000Hz	500kHz	3,000Hz	10,000Hz	500kHz
				<b>5 kW per sq. in.</b>					
Annealed	0.178	0.152	0.126	0.143	0.125	0.096	7.0	7.6	10.5
Normalized	0.144	0.137	0.110	0.108	0.096	0.088	6.4	7.5	10.5
Q & T	0.116	0.103	0.048	0.096	0.070	0.042	6.3	7.3	7.8
				<b>10 kW per sq. in.</b>					
Annealed	0.157	0.125	0.063	0.114	0.104	0.057	3.3	2.6	3.5
Normalized	0.122	0.105	0.062	0.093	0.089	0.057	3.2	2.6	4.0
Q & T	0.096	0.074	0.029	0.080	0.066	0.026	3.2	2.4	2.5
				<b>15 kW per sq. in.</b>					
Annealed	0.148	0.109	-----	0.110	0.094	-----	2.4	1.4	----
Normalized	0.114	0.085	-----	0.089	0.080	-----	2.5	1.3	----
Q & T	0.088	0.067	-----	0.072	0.062	-----	1.9	1.2	----

\* Depth at 50RC hardness

Because prior structure affects the response of the material, a quench and tempered part is optimum.

## Typical Temperature Profiles through Heat Treating

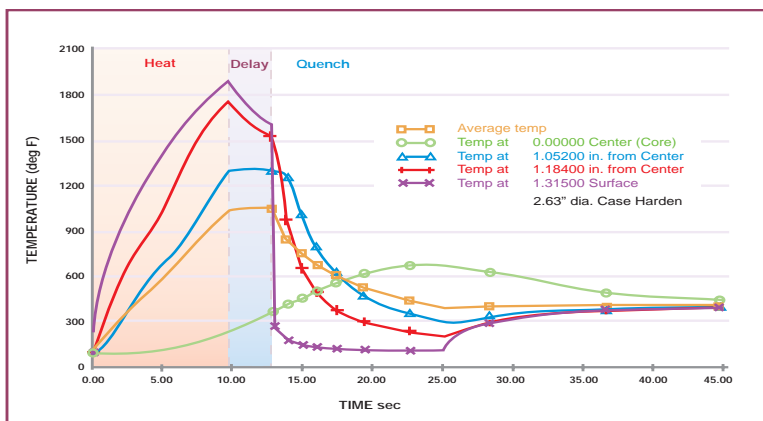

Time-temperature cycle for case hardened 2.63 in. diameter part showing temperature changes with time at indicated distances from center to surface of piece. Also illustrated is average temperature for various times during this surface hardening treatment.

## Quench Media for Hardening

Quench Media	Material
Water . . . . .	1030, 1035, 1040, 4130, 8630
Hot Water (110/130°F) . . . . .	Cast Iron
Polymer Quenches . . . . .	1030 - 1060 (4 to 20%) . . . . . 1130 - 1150
Soluble Oil . . . . .	1330 - 1350, 4030 - 4060, 4340, 8635, 52100
Forced Air . . . . .	4340 - 4345, 8640 - 8645
Still Air . . . . .	Annealed White Iron

# Detroit Development Center

## Process Development Expertise / Meeting Critical Timing Objectives

Ajax TOCCO provides the metallurgical, technical and product expertise to develop the tooling and process that will meet your product performance objectives in today's fast paced environment. Tooling can be manufactured and modified within days and the Induction Laboratory has a variety of inductors ready for immediate trials.



## Experience and Skills

The rapid heating cycles that make induction so attractive also offer new challenges for the metallurgist and process engineer. Ajax TOCCO Magnethermic development and process engineering group has the induction experience and know how to develop processes and equipment that is robust and at the forefront of technology.



Only Ajax TOCCO offers complete customer service from development and PPAP to ISO certified production heat treating capabilities.



One of the latest development tools utilizes FEA analysis to minimize development time.

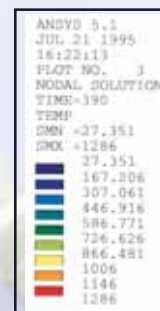

Full line of metallurgical preparation and inspection equipment including digital imaging staffed by qualified metallurgists.

Good results begin with a good plan, Ajax TOCCO has the "design of experiment" experience to optimize your prototypes and minimize your expenditures.

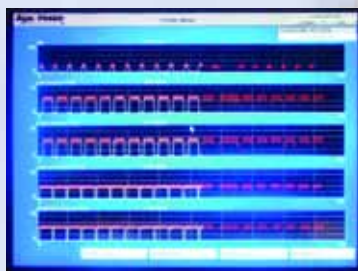

Ajax TOCCO facilities house the necessary monitoring and testing equipment for PPAP qualifications.



Computerized coordinate measuring equipment for precise dimensional verification.

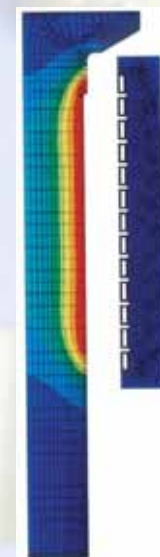

# Part Handling Mechanisms & Inductor Designs

Ajax TOCCO takes pride in designing and building machine tool precision material handling required for induction heat treating. Proper fixture design is essential in making it possible to attain desired productivity and to maintain the accuracy of the induction heating process.

The size and configuration of the work to be heated, the production rate that is required and the type of heating largely determine the work handling approach. Ajax TOCCO engineers are expert in analyzing heating applications to provide the most efficient, reliable and economical design.

Ajax TOCCO fixtures incorporate the handling mechanisms to accurately position the part in the inductor. Shown are a variety of methods for positioning, in which virtually any handling system, manual or automatic, can be adapted.

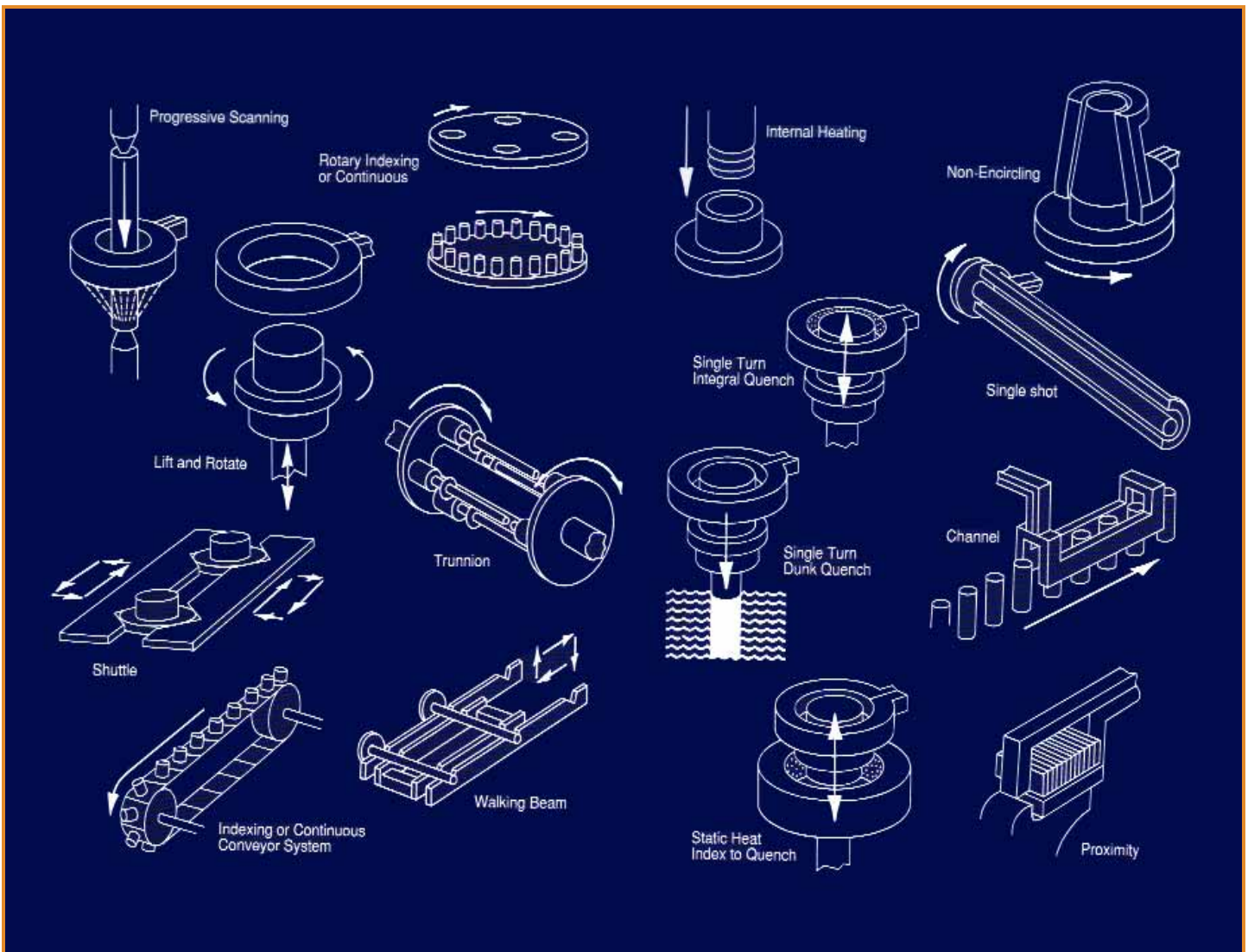

# Heat Treat Applications

## Variety of Effective Methods & Applications

Ajax TOCCO induction heat treating systems are being used successfully throughout the world for hardening, annealing, stress relieving, tempering, brazing, bonding, shrink fitting, and many other processes requiring fast, efficient and economical heating. These processes are being applied to virtually any shape of part ranging in size from fractions of an inch to substantial lengths and diameters.

With more than 90 years of technical development and experience, Ajax TOCCO's philosophy is to provide what customers want by analyzing their needs and recommending a system of maximum value to do the job reliably, faster and at the lowest cost.

Ajax TOCCO specializes in a wide range of heat treating applications including:

- Axles
- Bars and Tubes
- Bearings
- Camshafts and Crankshafts
- C.V. Joint Components
- Cylinder Liners
- Gears and Sprockets
- Hand Tools
- Mill Rolls
- Pins
- Pistons
- Shafts and Rods
- Valve Seats
- Wheels, Hubs and Spindles



# Applications

As proof of our continuous commitment to the industry, the following Ajax TOCCO installations are offered as examples of small and large, simple and sophisticated applications. Is there a process in your plant for Ajax TOCCO induction heat treating?

## Vertical Scanners



### Turbine Shafts

Turbine shafts are induction case hardened to a depth of 0.055" on a single spindle standard duty scanner (SD Scanpak). Magnescan JC controls provide recipe management. An operator loads and unloads parts at a rate of 54 parts per hour.



### Axles

Truck axle tube assemblies ranging to 4" in diameter and 40" long are induction hardened in Ajax TOCCO single and dual spindle heavy duty scanners.



### Input Steering and Compressor Shafts

Robots are used to load and unload Ajax TOCCO vertical scanners. This single spindle scanner automatically hardens power steering input shafts at 120 parts per hour. A separate spindle is provided for tempering.



### Steering Racks

Ajax TOCCO dual spindle medium duty scanners induction harden and temper automotive steering racks with 3 and 10 kHz. Robots load and unload parts to produce up to 80 parts per hour. Magnescan TQMS controls precisely control and monitor the induction energy and quench parameters.





## Vertical Scanners



### Pins

Pins ranging from 1" to 5" in diameter and up to 48" long are processed on Ajax TOCCO standard extra heavy duty scanners.



### Axles

Off-highway drive shafts and axles are hardened to case depths of 8-16mm. Frequencies of 1 to 3 kHz provide precise controls.



### Flanged Axles

Flanged axles for rear wheel drive automotive and truck applications are induction scan hardened on heavy duty vertical scanners. Inductors and quench utilize quick change tooling.

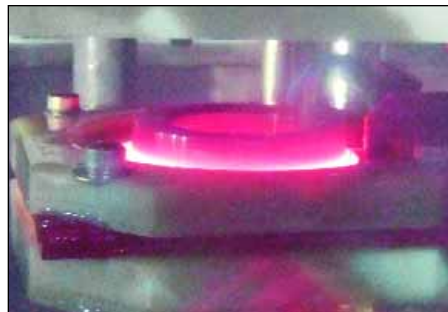

### Bearings

Bearings are induction through hardened on single and dual spindle scanners. Magnescan TQMS controls assure accurate repeatability and monitoring of parameters.

### Torsion Bars

Square shafts used for torsion bars are induction hardened and tempered on medium duty scanners.



# Applications

## Horizontal Scanners

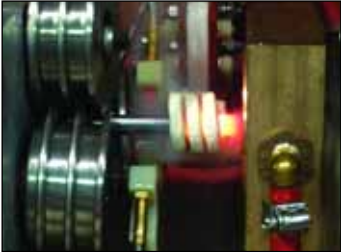

### Strut Shafts

Strut shafts are induction hardened and tempered using Ajax TOCCO spin feed systems. Parts are conveyed into variable speed skewed rolls to control forward motion. Case depths of 1-2 mm are typical.



### Shafts

Chrome shafts used for cylinder rods and linear shafting ranging from 1" to 4" diameter up to 25' long are induction hardened utilizing drum roll scanners. Ball screws are also hardened on similar systems. These horizontal fixtures provide independent rotation speed and precision forward motion to minimize distortion. Magnescan TQMS controls include recipe management to precisely control hardened areas including skip hardening.



### Rolls

Drum roll scanners induction harden and temper mill rolls ranging up to 8" diameter and to 14' long. The fixture provides deep case hardening of the body and shallow case hardening of the journals.



### Pipe & Tube

Quench & Temper lines are capable of continuously producing heat treated long products in capacities exceeding 36 tons per hour.



### Axle Shafts

Heavy construction drive shafts are deep case induction hardened using Ajax TOCCO horizontal lathe type scanners. Shafts up to 4" diameter and 180" in length are processed using driven head and tail stocks with steady rests to support the part during hardening and load/unload.



### Bar

Solid bars – 20' long and ranging from 7/8" to 3-1/2" in diameter – are austenitized, quenched and tempered continuously on this in-line induction system at a rate of 3 tons per hour.

## Single Shot & Static



### Output Shafts (Vertical)

Transmission output shafts ranging up to 20" in length are single shot induction hardened and tempered on single spindle and two station vertical systems. Part position is servo controlled for heating and quenching. Process control and monitors assure repeatability using signature profiles of critical data. Production rates up to 80 parts per hour are achieved using robot loading.



### Drive Shafts (Horizontal)

Drive shafts are single shot induction hardened up to 18 times faster than scan systems. Parts ranging from 12 to 36" are magazine loaded into a horizontal spindle for single shot hardening at production rates up to 170 parts per hour. Parts are quenched and conveyed to the machine discharge for customer acceptance.

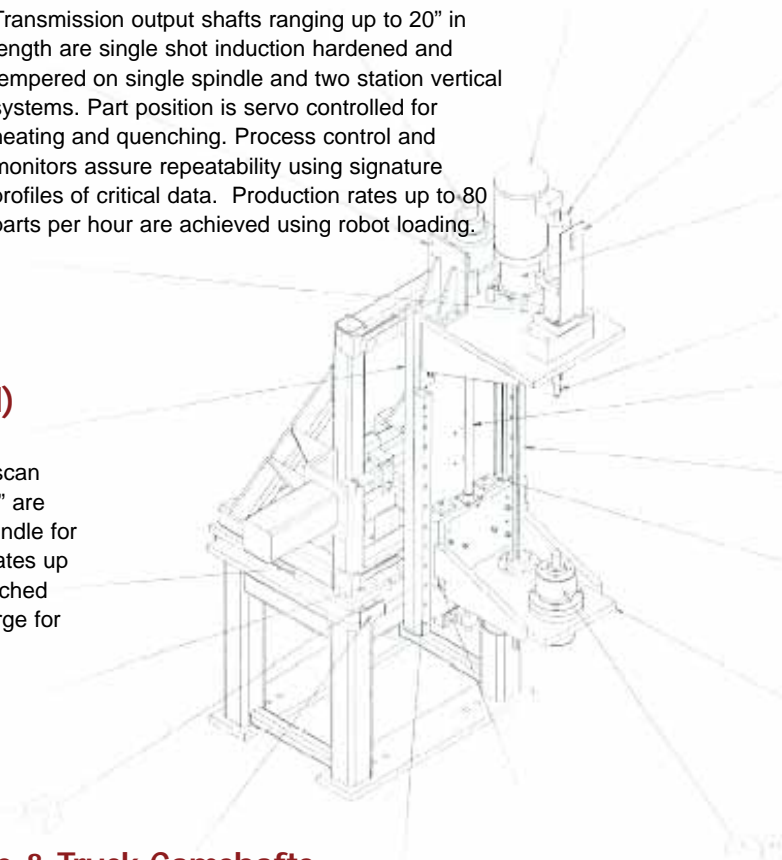

## Camshafts

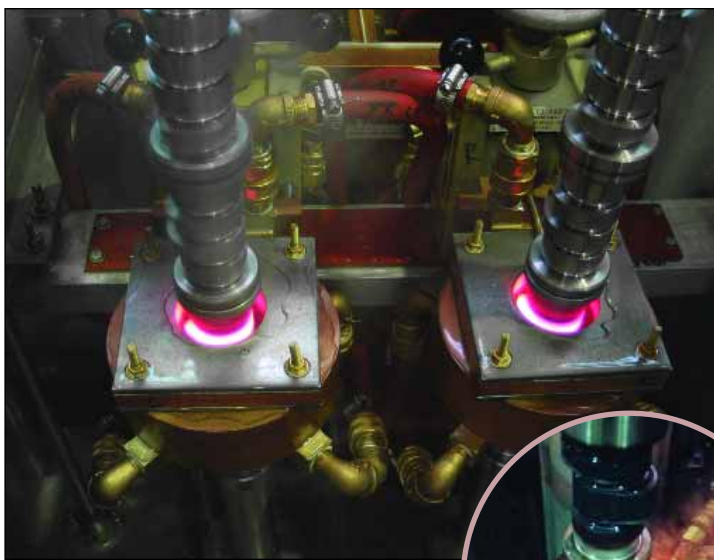

### Automotive & Truck Camshafts

Automotive camshafts are induction hardened on single and dual spindle vertical scanners. Lobes and journals are processed in a variety of methods including single loop and multi-loop inductors, integral and barrel quenches..



### Locomotive Camshafts

Vertical scanner for locomotive camshaft journal and lobe hardening.



# Applications

## Manual Fixtures



### Turbine Shafts

Carburized threads are annealed using single station manual loaded fixtures.

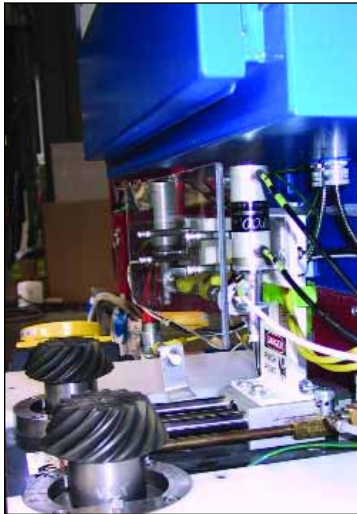

### Pinion Threads

Carburized threads are annealed using dual station manual loaded fixtures. The process is monitored using both energy and infrared temperature.

## Lower Rotate Fixtures



### Flywheel Ring Gear

Flywheel ring gears are induction hardened and tempered using single spindle lower rotate fixtures. Parts are automatically transferred through the heat treat station at rates up to 170 parts per hour.



## Lift Rotate Fixtures

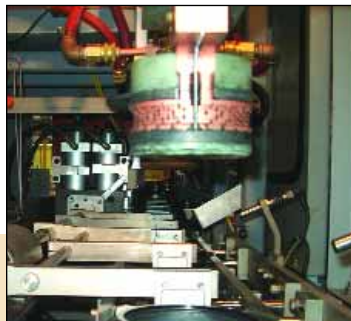

### Outer Race

Inside diameter surfaces of transmission outer races are hardened and tempered on two station lift rotate fixtures. A shuttle transfer indexes parts through the spindles.



### Wheel Spindles & Hubs

◀ Single spindle rotation fixtures harden wheel spindles and hubs at rates up to 300 parts per hour. Parts are loaded directly into the spindle or onto a turntable using a pick & place mechanism.

Parts are conveyor tempered using a channel inductor to match the harden cycle. ▶



# Special Applications

## Tooth x Tooth



### Sprockets

Sprockets for heavy construction equipment are hardened two at a time utilizing the tooth-by-tooth hardening method followed by a submerged quench.



## High Volume



### Bearing Pins & Axles

Bearing pins and axles are induction hardened on Ajax TOCCO single, dual and triple lane systems. Production rates range up to 3600 parts per hour.

## Dial Index Tables



### Wheel Hubs

Wheel hubs, transmission races, hand tools, gears and mining tools are processed using turntables. These turntables are used for hardening, tempering and annealing parts with multiple processes or high production rates.



### Spur & Helical Gears

Tooth-by-tooth hardening of large spur and helical gears ranging to 180" diameter are processed on Ajax TOCCO designed machines. Gears can weigh up to 15,000 pounds. The three axis controls precisely control inductor and part movement to assure consistent case depths on each tooth.

## Crankshafts

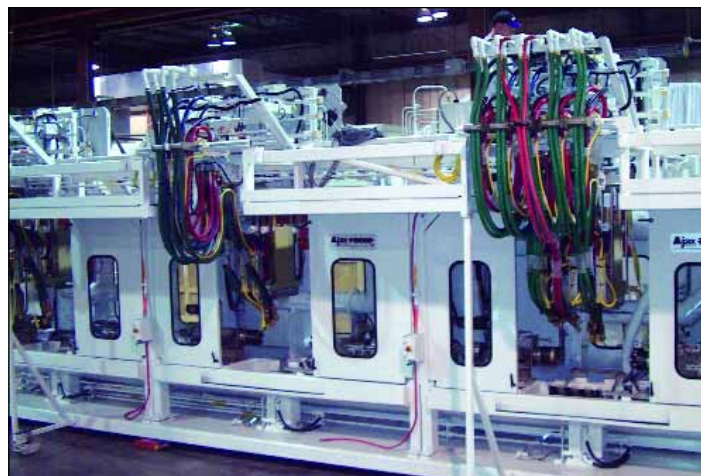

### Journals & Pins

Truck engine crankshaft main journals and pins are induction hardened on a three station cell. Station one hardens the mains, stations two and three harden the pins. The system has five power supplies which are shared between the three stations. The cell stations are robotically loaded and unloaded.

# Controls & Monitors

## Magnescan TQMS Controls

Ajax TOCCO's premiere control for heat treating applications is our Magnescan TQMS (Total Quality Monitoring System). This control provides a touch screen HMI with PC interfaced to a PLC and Servo for controlling all operating parameters on the system. Power supply functions, energy levels, scan speeds and position, quench temperatures, cycle times, rotation speed, etc., are all controlled with this system. In addition, the system monitors all of these functions, stores all critical parameters for each part and provides for SPC data manipulation and graphing. Part recipes are stored in the PC and storage is only limited by hard drive capacity. All hardware and process alarms are displayed and stored for future reference. System diagnostics, as well as equipment drawings and manuals are stored for maintenance or operator use. Multiple screens display equipment status, process status, part recipes, SPC functions, and much more.



## Parameters Screen

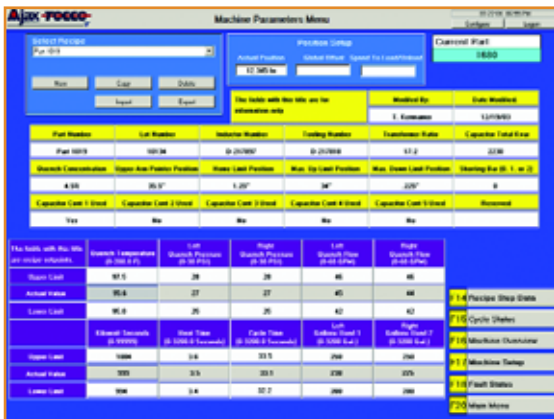

## Process Monitor

The Process Monitor is a stand-alone package available for equipment retrofit that provides all of the monitoring features of the Magnescan TQMS package without the control. The existing equipment controls are retained for equipment functions, however most of these functions can be monitored by the process monitor, including energy levels, where they are stored and manipulated for SPC just as in the TQMS control package.

## Recipe Screen



## Profile Screen

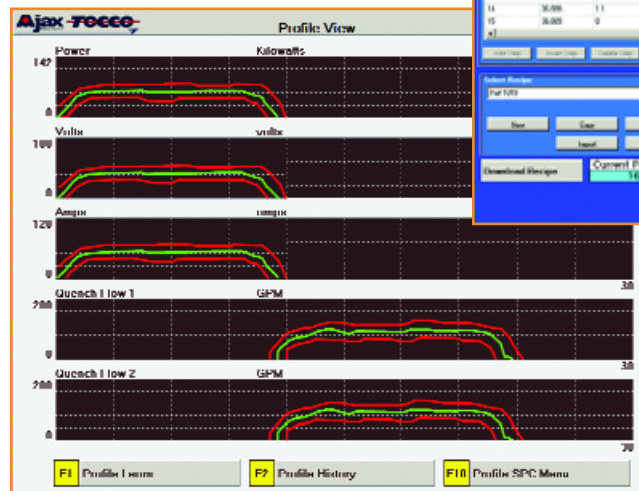

## Custom Controls

Ajax TOCCO Magnethermic maintains an expert staff of controls engineers who have the capability to design custom control packages for any type of process control. Any control package from the very basic to the most sophisticated can be developed for your application.

# Power Supplies

## Power to Spare

Ajax TOCCO Magnethermic has lead the way in developing and improving induction power supplies. Our frequency line ranges from 50 Hz to 450 kHz to cover your application needs. With the Pacer® series you gain flexibility allowing you to heat a wide range of parts, covering a wide frequency range with one power supply. With the Inductron series the MPC control allows for part recipes, easy power supply setup, and diagnostics through the operator interface.



Low Profile Pachydyne®

Ajax TOCCO's line of single bridge, multiple inverter power supplies allows for floor space savings and reduced installation costs that are necessary with installations that require multiple power supplies.

The TOCCOtron series provides solid state power for frequencies up to 400 kHz and with power levels as low as 5 kW. Many of these units are air cooled. High power, high frequency oscillators are offered for applications requiring frequencies in excess of 200 kHz.

Ajax TOCCO's newest DSP logic provides digital power supply control. All power supply functions and setup are accomplished through the HMI display. Diagnostics, including waveforms, can be viewed through the HMI or sent to a remote PC for troubleshooting.



TOCCOtron® AC



TOCCOtron® 400



Pacer® II

Pacer® S-10



Pacer® T

Inductron® II  
TOCCOtron® SS



Inductron® PT

# Ajax TOCCO is a full service company serving the world's heat treating industries.

## Leader in Induction Technology

Ajax TOCCO Magnethermic, one of the oldest and most experienced manufacturers of induction heating and melting equipment, recognizes the need to continually improve induction technology and discover better ways to utilize the induction process to serve industry. Our continued drive in induction technology and research has made us the world leader with more firsts than all other induction manufacturers combined.

## Research & Development

Ajax TOCCO maintains full-time research and development teams having complete facilities for metallurgical, electronic, and mechanical testing. Our facilities feature induction and testing equipment for the latest developments in electronics technology and process development

## New Product Development

Through our commitment to research and development. Ajax TOCCO continually works to enhance existing technology and discover new and better methods to utilize the induction process. Ajax TOCCO works closely with their customers to develop prototype programs, feasibility studies, and often will make actual production runs.

## Design Integrity

Ajax TOCCO is a leader in the development of process control systems and designs for the induction process. Some examples include our Magnescan TQMS process control and quality monitoring package available on all of our heat treating systems. Another example is in heat treating inductors including our latest designs for crankshafts. Our experience enables us to provide technologically advanced systems which specifically meet our customer's present and future needs.

## Technical Training

Ajax TOCCO is committed to helping its customers get the most from their investment. To achieve this, Ajax TOCCO offers extensive training programs, available to all customers. These include in-house training at Ajax TOCCO, on site schooling, web training, web troubleshooting, and a comprehensive aftermarket care program.

## Worldwide Service

Ajax TOCCO customers span the world. Our customer care initiative insures that Ajax TOCCO Service Engineers worldwide are trained, experienced technicians capable of determining and handling even the most difficult of problems, many of which can be solved with telephone assistance. A Service Engineer is never more than hours away.



## Repair Centers

Ajax TOCCO maintains a network of repair centers and service facilities located around the world. If your need is for field service, inductor and transformer repairs, parts, or preventative maintenance there will be an Ajax TOCCO facility nearby to assist.

**Call 1-800-547-1527, 24/7 for Service Assistance.**



Authorized OEM for AIH, IEH, Ajax Magnethermic®, and TOCCO®

### Ajax TOCCO Magnethermic® Corporation

*The Global Force in Induction Technology*

#### World Headquarters

1745 Overland Ave  
Warren, OH 44483  
330-372-8511  
330-372-8608 (FAX)

[www.ajaxtocco.com](http://www.ajaxtocco.com)